

Drawings remain our exclusive property. They are emitted only for the agreed purpose. Copies or any other reproduction, including storage, treatment and dissemination by use of electronic systems must not be made for any other than the agreed purpose. Neither originals nor reproductions may be given to or made available to third parties.

Die Zeichnung bleibt unser ausschließliches Eigentum. Sie wird nur zu dem vereinbarten Zweck anvertraut und darf zu keinem anderen Zweck verwendet werden. Kopien oder sonstige Vervielfältigungen einschließlich Speicherung, Verarbeitung oder Verbreitung unter Verwendung elektronischer Systeme dürfen nur zu dem vereinbarten Zweck angefertigt werden. Weder Original noch Vervielfältigungen dürfen Dritten zugänglich oder in sonstiger Weise zugänglich gemacht werden.

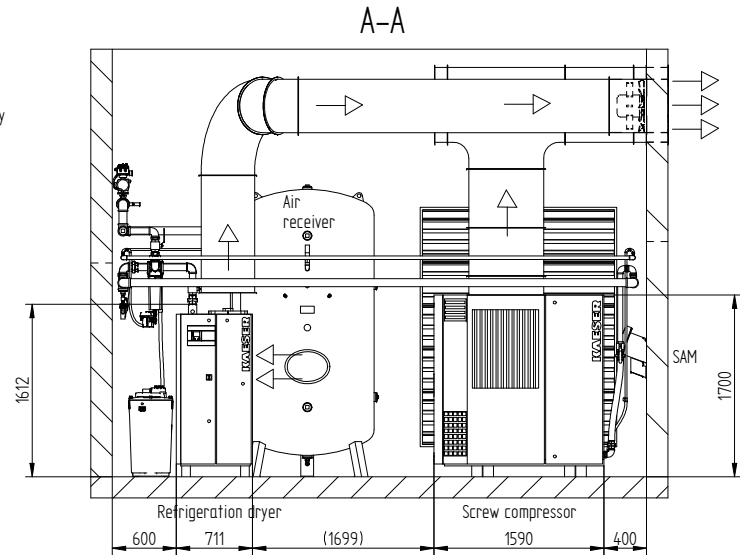

Design limits for ambient temperature
min.: + 3° C
max.: + 40° C

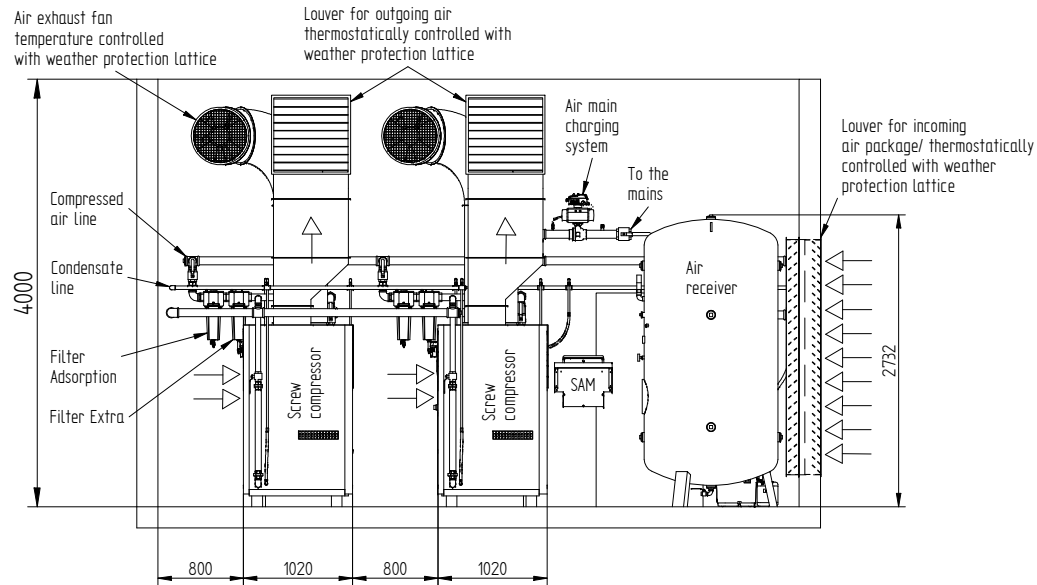
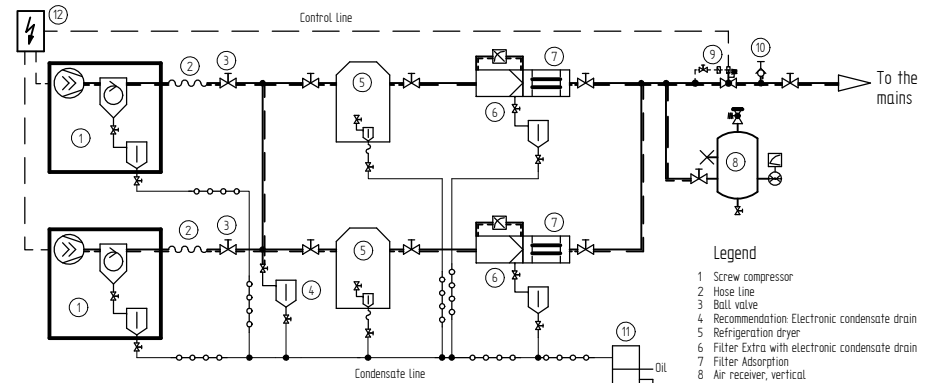
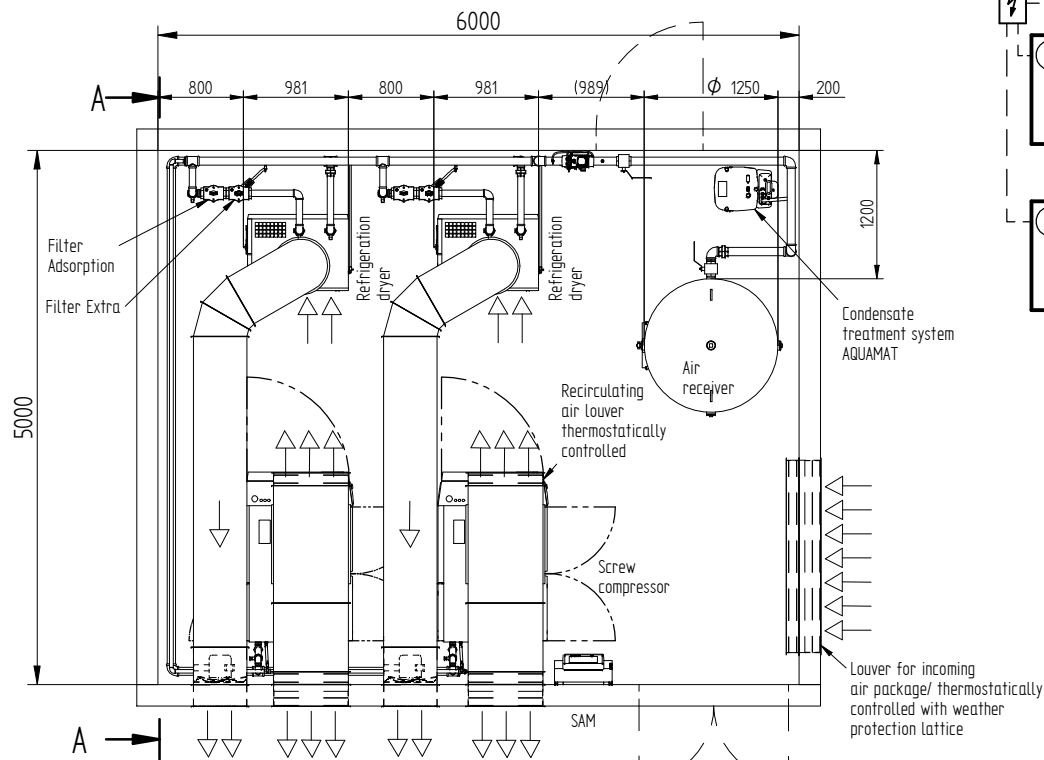

Condensate lines have to be connected to a collecting line via swan neck or are to be fed to the condensate treatment system separately. A pressure-less drain has to be provided.

This drawing also contains work to be done on site. The regulations of EN 1012 and national regulations for setting up of power installations like VDE 0100 have to be observed; the requirements of existing operational safety ordinance and the manuals have to be considered by the operator and the employer respectively at the place of installation. The national safety and accident prevention regulations have to be observed. The installation of a sub- assembly in terms of the pressure equipment directive 2014/ 68/ EU has to be carried out according to this directive.

ATTENTION!
Minimum width of door is total component width + 100 mm

Technical data see page 2

KAESER KOMPRESSOREN	P + I	Scale	Date	Name
	<input checked="" type="checkbox"/> Inst.	1:50	26/09/2016	Nahas1
Template Rev. 17.07.2013	<input checked="" type="checkbox"/>	DIN A3	Checked	26/09/2016
Description	Sample layout sketch // 40° C		Plan No.	
2x BSD with exhaust air duct		LYMU0007301e		
IShown 2x BSD 83, 2x TE 142, 2x F 83 KE, 2x F 83 KA)		Page 1 of 2		

Drawings remain our exclusive property. They are emitted only for the agreed purpose. Copies or any other reproduction, including storage, treatment and dissemination by use of electronic systems, must not be made for any other than the agreed purpose. Neither originals nor reproductions may be given to or made available to third parties.

Die Zeichnung bleibt unser ausschließliches Eigentum. Sie wird nur zu dem vereinbarten Zweck anvertraut und darf zu keinem anderen Zweck verwendet werden. Kopien oder sonstige Vervielfältigungen einschließlich Speicherung, Verarbeitung oder Verteilung unter Verwendung elektronischer Systeme dürfen nur zu dem vereinbarten Zweck angefertigt werden. Weder Original noch Vervielfältigungen dürfen Dritten ausgemittelt oder in sonstiger Weise zugänglich gemacht werden.

Compressor model	Working pressure [bar(g)]	Compressed air connection	Air entrance aperture free cross section per unit [m ²]	Incoming air volume per unit [m ³ /h]	Air exhaust duct dimensions (free cross section) per unit [m ²]	Permissible overall pressure loss for exhaust duct per unit Δp [Pa]	Compressed air collective line (two units)	Water trap ECO-DRAIN a)	Refrigeration dryer model	Compressed air connection	Air entrance aperture (free cross section) per unit [m ²]	Incoming air volume per unit [m ³ /h]	Exhaust air fan (thermostatically controlled) per dryer [m ³ /h]	Filter Extra	Compressed air connection	ECO-DRAIN a)	Filter Adsorption	Compressed air connection	Air receiver [l]	Compressed air connection	Control	Air main charging system	Compressed air connection	Condensate treatment unit AQUAMAT a)
BSD 65	8.5	G 1 1/2	0.8	6840	0.49	60	DN 65	32	TD 76	G 2	0.3	3480	3480	F 83 KE	G 1 1/2	31 F	F 83 KA	G 1 1/2	3000	G 2½	SAM 4.0	DHS 65 G	G 2 1/2	CF 19
BSD 75	8.5	G 1 1/2	1	8420	0.49	60	DN 65	32	TE 102	G 2	0.4	3040	3040	F 83 KE	G 2	31 F	F 83 KA	G 2	3000	G 2½	SAM 4.0	DHS 65 G	G 2 1/2	CF 38
BSD 83	8.5	G 1 1/2	1.2	8490	0.49	60	DN 65	32	TE 142	G 2	0.4	3040	3040	F 83 KE	G 2	31 F	F 83 KA	G 2	3000	G 2½	SAM 4.0	DHS 65 G	G 2 1/2	CF 38

Design limits for ambient temperature
min: + 3° C
max: + 40° C

a) Climatic zone 2

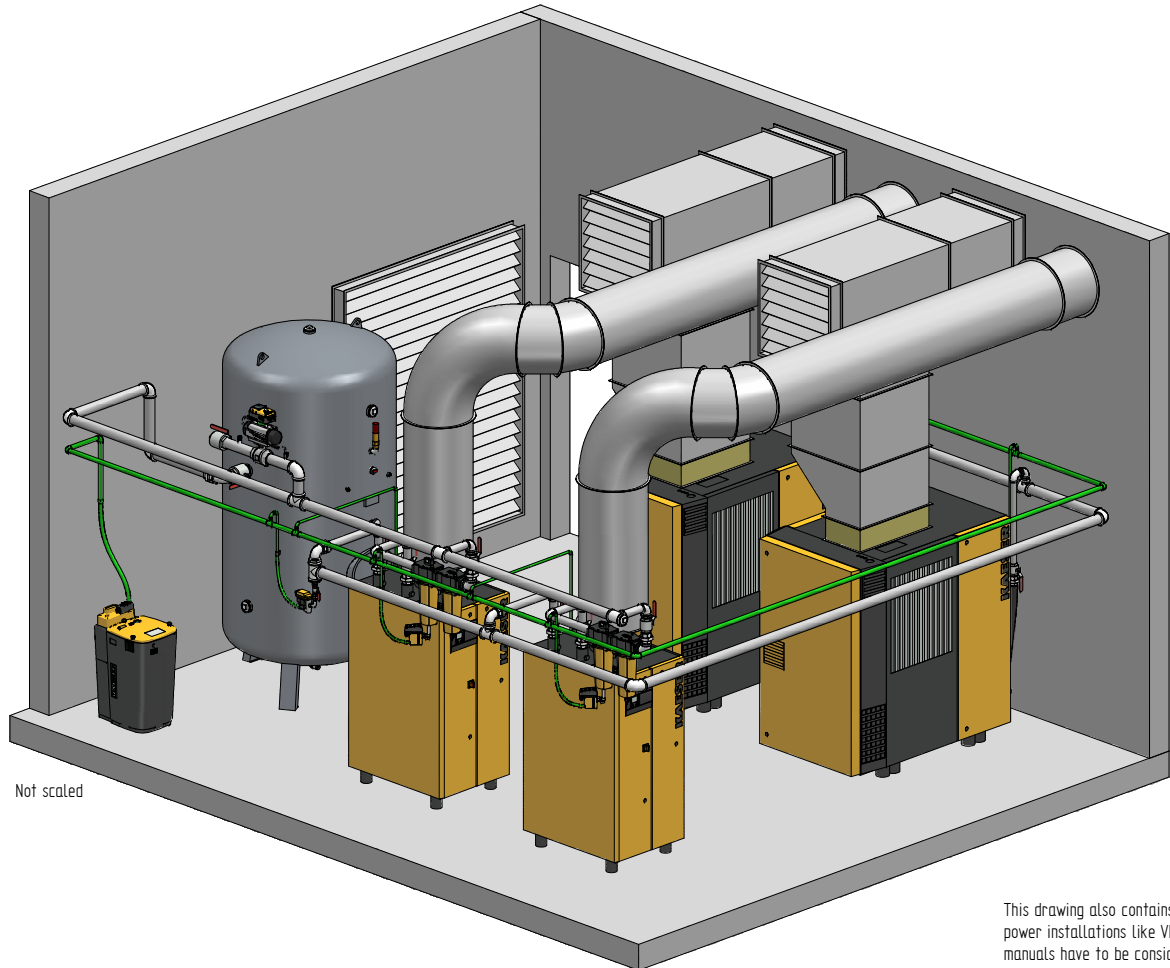

Not scaled

Air receiver represents minimum recommended size

This drawing also contains work to be done on site. The regulations of EN 1012 and national regulations for setting up of power installations like VDE 0100 have to be observed; the requirements of existing operational safety ordinance and the manuals have to be considered by the operator and the employer respectively at the place of installation. The national safety and accident prevention regulations have to be observed. The installation of a sub-assembly in terms of the pressure equipment directive 2014/ 68/ EU has to be carried out according to this directive.

KAESER KOMPRESSOREN	P + I <input checked="" type="checkbox"/>	Scale 1:50 DIN A3	Date	Name
	Inst. <input checked="" type="checkbox"/>		Drawn	26/09/2016 Nahhas1
Template Rev. 17.07.2016			Checked	26/09/2016 Hobusch
Description Sample layout sketch // 40° C 2x BSD with exhaust air duct IShown 2x BSD 83, 2x TE 142, 2x F 83 KE, 2x F 83 KA			Plan No. LYMU0007301e	
			Page 2 of 2	

ATTENTION!
Minimum width of door is total component width + 100 mm

Condensate lines have to be connected to a collecting line via swan neck or are to be fed to the condensate treatment system separately. A pressure-less drain has to be provided for.